

OSR 300H

**High Speed Mark Reader
with Integrated Camera and Sorting Stacker**

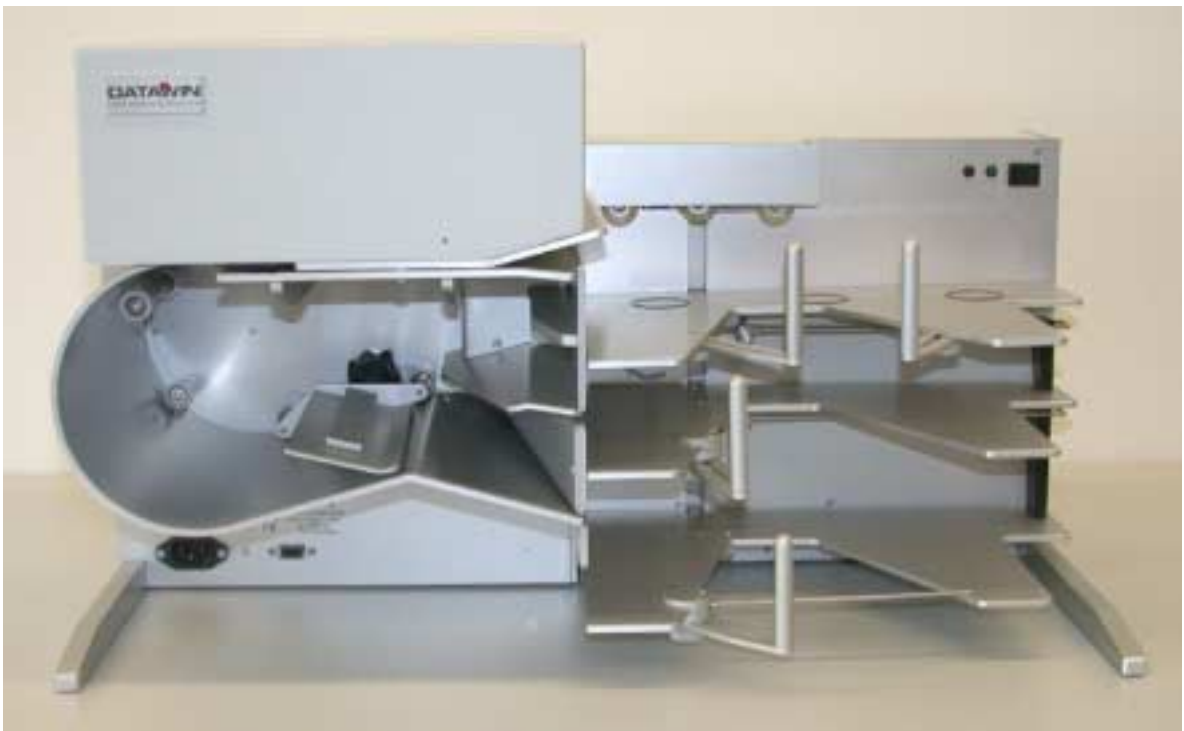

User Manual

Publisher:

DATAWIN GmbH

Etzstrasse 37

D-84030 Ergolding

Tel. : + 49 (0)871-43 05 99 0

Fax: + 49 (0)871-43 05 99 29

Email: service@datawin.de

Web: <http://www.datawin.de>

Printed in Germany

Subject to alteration

Windows is a registered trademark of the Microsoft Corporation.

Copyright © DATAWIN GmbH

All rights reserved

This manual is the intellectual property of DATAWIN GmbH.

Unauthorized use, duplication or distribution is prohibited.

Any reproduction of the contents of this manual, in whole or in part, without written permission of DATAWIN GmbH is forbidden.

Edition September 2006/1.2

Table of Contents

1	Introduction	1-1
1.1	About this manual.....	1-1
1.1.1	Typographical notes	1-1
1.2	Information about unpacking the mark reader.....	1-2
1.2.1	Scope of the delivery	1-3
1.3	Device related safety information.....	1-4
1.3.1	Conformity	1-4
1.3.2	Precautionary measures for transportation, storage and installation	1-4
1.3.3	Selection of the work site.....	1-5
2	The OSR 300H scanner and mark reader.....	2-1
2.1	Functional components.....	2-1
2.2	Document processing – from intake to output.....	2-3
2.2.1	Automatic document intake.....	2-3
2.2.2	Document transport path	2-4
2.2.3	Camera system	2-6
2.2.4	OMR read head.....	2-7
2.2.5	Bar code read head	2-7
2.2.6	MICR module.....	2-7
2.2.7	LED display and tray button.....	2-8
2.2.8	Optional printer	2-8
3	Preparing and installing the reader.....	3-1
3.1	Attaching the inclined adjustable feet.....	3-1
3.2	Attaching the document stoppers	3-2
3.2.1	Intake tray.....	3-2
3.2.2	Output trays.....	3-2
3.3	Inserting ink cartridges in the (optional) printer	3-3
3.4	Mains connection data.....	3-3
3.5	Interfaces.....	3-4
3.5.1	USB interface	3-4
3.5.2	Serial interface.....	3-4
3.6	PC connection	3-4
3.6.1	Minimum requirements on the PC.....	3-4
3.6.2	Installing the software	3-4
3.6.3	Connecting the reader and the PC.....	3-4
3.7	Testing the read functions	3-5
3.7.1	Camera test.....	3-5
3.7.2	OMR test	3-5
3.7.3	Starting the read process.....	3-5
3.8	De-installing the reader.....	3-6
4	Operation of the reader	4-1
4.1	Loading the stack of documents	4-1
4.2	Starting the read process.....	4-2
4.2.1	Display of the operating status.....	4-2

4.3	Eliminating document jams	4-3
4.3.1	Opening and closing the scanner cover	4-3
4.3.2	Removing documents	4-4
4.4	Trouble shooting	4-5
5	Setting, adjusting and cleaning the reader	5-1
5.1	Setting the OMR read head	5-1
5.1.1	Basic setting "standard document"	5-1
5.1.2	Adjusting the lateral setting of the OMR read head	5-2
5.1.3	Adjusting the lateral setting of the lower OMR read head (option)	5-3
5.1.4	Effect of the read head setting on the scanning result	5-4
5.2	Setting the bar code read head (option)	5-5
5.3	Setting the document isolation	5-6
5.3.1	Cleaning the separating belt	5-7
5.4	Replacing ink cartridges in the printer	5-8
5.5	General information on cleaning the OSR 300H	5-10
5.5.1	Cleaning the transport rollers	5-11
5.5.2	Cleaning the light barriers	5-11
5.5.3	Cleaning the read windows (camera, OMR and bar code)	5-11
5.5.4	Cleaning the MICR module (option)	5-11
5.5.5	Cleaning the housing surface	5-12
6	Requirements on the documents	6-1
6.1	External characteristics	6-1
6.2	Prescriptions and recommendations concerning OMR marks	6-2
6.2.1	The mark field	6-2
6.2.2	Correct marks	6-3
6.2.3	Inadmissible marks	6-3
6.2.4	Reliable marking instruments	6-4
6.3	DATAWIN OMR document specifications	6-5
6.3.1	Standard document	6-5
6.3.2	Scanning window	6-7
6.3.3	Bar codes labels and imprints	6-8
6.3.4	Permissible document colors for red light and infrared light scanning	6-9

1 Introduction

1.1 About this manual

This manual is intended for users who are entrusted with the setting up, installation and operation of the OSR 300H optical mark reader (OMR = Optical Mark Recognition).

- **Part 1** provides information about
 - unpacking and storing the device and device related safety information
 - connection to the mains source and authorization as well as
 - the requirements on the operating environment.
- **Part 2** informs you about
 - the most important functional components, their designations and arrangement as well as
 - the main mode of operation.
- **Part 3** describes
 - the preparations for initial operation and also
 - the installation of the OSR 300H - from connection to the PC up to conducting a test run.
- **Part 4** provides tips and information to facilitate faultless operation of the OSR 300H.
- **Part 5** shows how you can increase the reading reliability:
 - by mechanical adjustments in the reader and
 - by a simple cleaning procedure of the OSR 300H.
- **Part 6** contains the document specifications and information on the marks.

1.1.1 Typographical notes

- ! This symbol calls your attention to particular items that absolutely must be observed.
- ◆ This symbol always appears before process sequences and it simultaneously indicates the chronological sequence.

1.2 Information about unpacking the mark reader



The reader lies with its back side towards the bottom inside the packaging. The accessories are to be found in the separate packaging.

- ◆ Lift the cover along with the attached filling materials vertically out of the packaging.
- ◆ Tip the box carefully onto its side so that the reader is standing on its adjustable feet. Now grasp the reader by its feet and pull it out of the box along with the filling materials.



! When carrying the reader as well, it is best to grasp it only by the adjustable feet. The device weighs about 24 kg.

- ◆ Remove the transportation lock of the camera and the two foamed strips in the output trays.

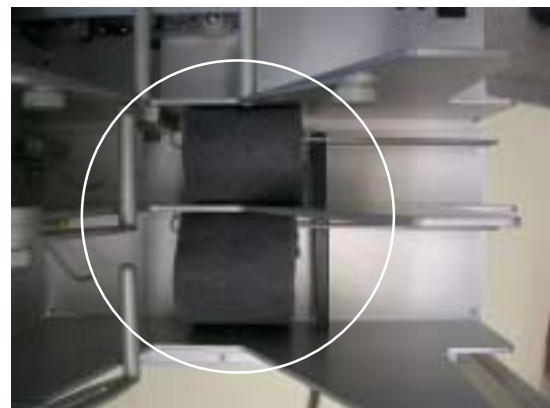

- ! Save the entire original packing for later transportation and shipping of the mark reader and the sorting stacker.
Devices that are sent back to suppliers for maintenance or repair work are always returned in their original boxes (possibly at cost of the sender).

1.2.1 Scope of the delivery

Check to make sure that the delivery is complete. All accessories required for the connection and operation of the OSR 300H are included in the delivery:

- mains cable
- data cable
- tools
- CD ROM with installation software and manual

If something is missing or if damages occurred during transportation, please contact your supplier.

1.3 Device related safety information

1.3.1 Conformity

The OSR 300H reader conforms to the CE standards and guidelines for data processing devices (design according to VDE 0805/5.90, interference suppression according to VDE 0871-B). It can be operated continuously under normal room conditions.

1.3.2 Precautionary measures for transportation, storage and installation

Please observe the following points regarding the transportation and installation of the reader:

Transportation and storage

- ! Transportation of the reader should only be effected in the original packing. It protects against shocks and inadmissible strains on the mechanical parts.
- ! Please take the ambient conditions into consideration when transporting or storing the reader.

Mains connection and authorization

- ! The reader may only be operated when connected to a grounded shockproof outlet. Industrially operated mains networks often exhibit substantial, load-dependent interference peaks (powerful motors, electrical welding plants, etc.). The OSR 300H reader is protected against such interference to a great extent, but if interference is present, try to use a network used for EDP or select a mains supply that is free of interference.
- ! Make sure that the mains voltage that is present corresponds to the required values stated on the type plate.
- ! Never open the housing of the reader and never remove any housing parts.
- ! Always turn the reader off via the mains switch before carrying out any adjustments or cleaning operations.
- ! It is forbidden to effect changes or modifications to the reader that are not stated in this manual. The manufacturer of the device will decline any form of guarantee demand and will not accept any service clauses if it can be demonstrated that the reader was manipulated or damaged by unauthorized persons.

1.3.3 Selection of the work site

Take care to assure that the OSR 300H is exposed to appropriate operating conditions. This is important in assuring faultless functioning of the reader:

- ! The reader must stand on a stable, horizontal and level surface. Its dimensions are 630 x 360 x 300 (L x W x H in mm); the reader weighs about 24 kg. Vibrations at the work site should be avoided.
- ! The permissible ambient temperature for operation of the reader is +10° C to +40° C (50° F to 104° F). Therefore, check to assure that the device is shielded against sources of heat such as direct sunlight, radiators, spotlights or other sources of light that produce heat.
Sunlight or foreign sources of light applied to the scanning unit under unfavorable circumstances may also have an influence on the read sensitivity.
- ! The permissible relative humidity amounts to 40 - 60%, condensation-free.
- ! It must be possible to lay all cables (mains cable and data cable) without buckling and without tensile stress. Take care to identify stumbling pitfalls.
- ! The OSR 300H corresponds to the requirements regarding interference emission and resistance to jamming (ESD) as specified by the CE guidelines. In order to assure complete interference immunity, shielded data cables with connector casings of metal or with metallic connector casings must be used.
- ! Take care that the device is not operated in surroundings that are contaminated by dust or oil. Air currents caused e. g. by windows that are continually left open, by passageways or ventilators, may lead to the increased production of dust and this in turn may necessitate shorter maintenance and cleaning intervals.
- ! The work site must afford sufficient space for the handling of the documents.

2 The OSR 300H scanner and mark reader

This chapter provides information about the most important system components, their designations and arrangement and describes the basic mode of operation. The uniform designation employed here in the description of the individual components of the reader will simplify understanding of the technical processes, of the operation of the device and of the maintenance work.

2.1 Functional components

The OSR 300H mark reader is a scanner and OMR optical mark reader with stack feed and two sorting stacker trays. It was designed as a high-capacity reader with the greatest possible operating ease for efficient data input. As options, the device can be equipped with

- a second OMR read head for the simultaneous reading of the front and rear sides of a document,
- a two-line bar code read head adjustable across the entire width of the document,
- an MICR module (then without the OMR read head)
- an ink jet printer (HP ink jet printer),
- a multiple line display for user guidance.

The two following figures show the components of the reader that are most important for operation.

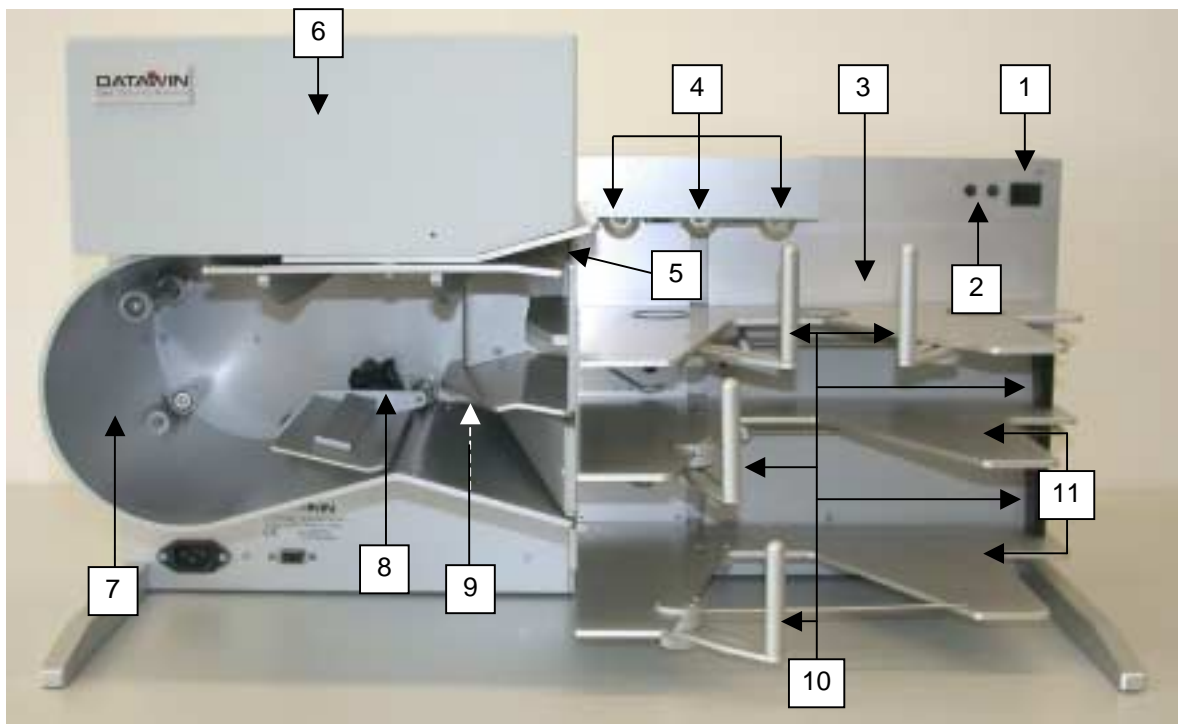

- 1 Button for the document intake tray
- 2 Display of the operating status
- 3 Document intake tray
- 4 Feed rollers
- 5 Automatic document intake
- 6 Upper scanner cover
- 7 Curved baffle plate
- 8 Optional printer
- 9 Sorting deflector
- 10 Adjustable document stoppers
- 11 Document output trays
- 12 Intake roller
- 13 Separating belt
- 14 Transport rollers
- 15 OMR read window
- 16 Bar code read window
- 17 Camera window

This figure shows the OSR 300H reader with opened scanner cover:

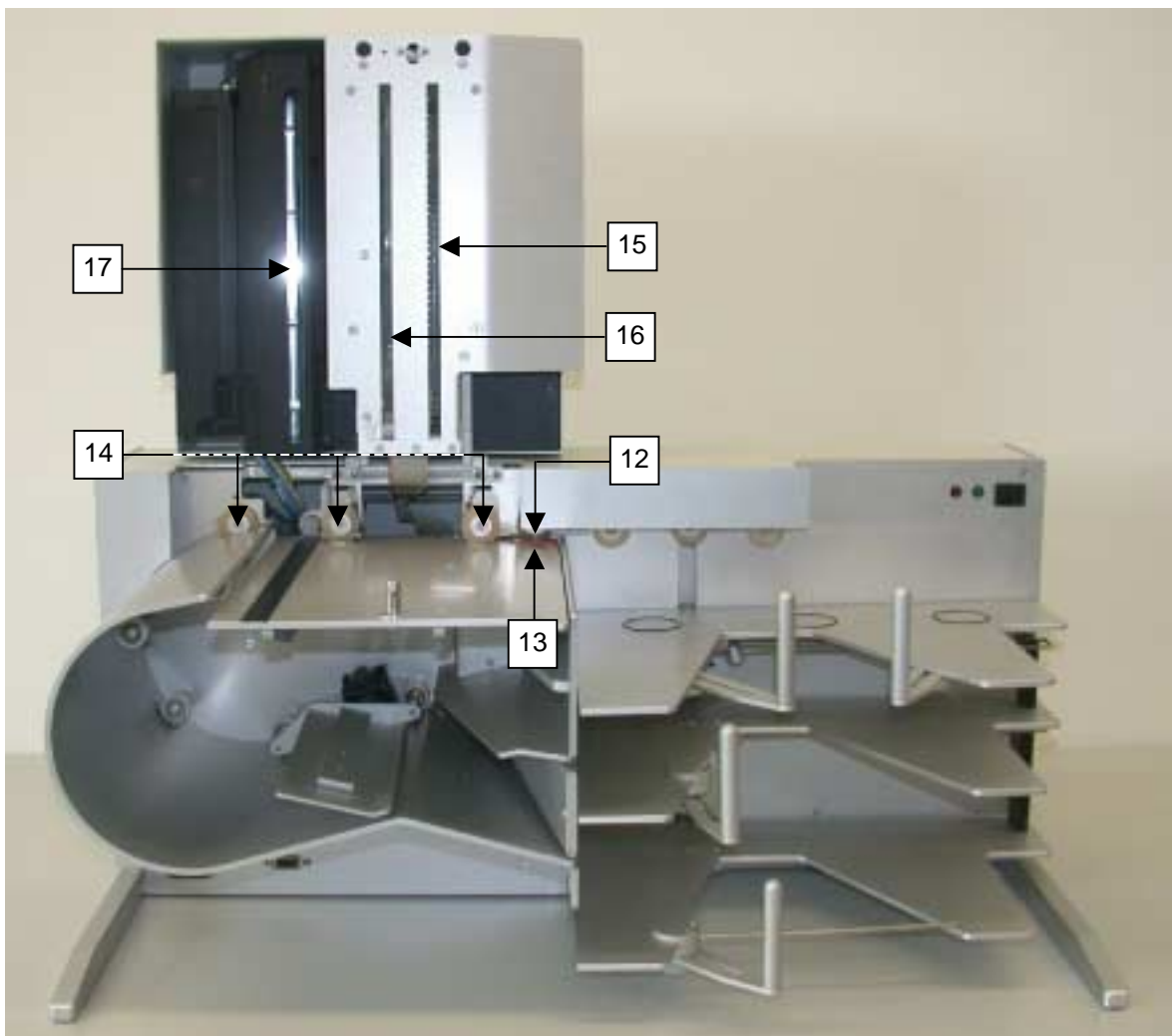

2.2 Document processing – from intake to output

2.2.1 Automatic document intake

The documents are automatically fed in from a stack on the document intake tray. The topmost sheet is thereby "pulled off". A special intake system consisting of three feed rollers, one intake roller and a reverse belt, the so-called separating belt, assures the safe "isolation" of the documents. All the rollers are fitted with silicone rings.



The three feed rollers are positioned at a slight slant to the feed direction and they thus bring the top document into a position pressing against the back stopper. You can set the interval between the separating belt and the intake roller according to the thickness of the documents in use.

The presence of documents in the intake tray is monitored by a light barrier. When the reader starts operation the intake tray moves upwards and the light barrier is queried. Only if at least one document is present in the intake tray is the document transport started. (If the intake tray is empty, it moves down to the bottom again.) A second light barrier is responsible for double document detection. After the last document has been processed, the read process is stopped and the intake tray moves down to the bottom again.

2.2.2 Document transport path

The documents that are drawn in individually are moved across transport rollers whereby they successively pass the read stations and the camera system. The transport speed amounts to up to 1.2 m/s, the read rate lies at a max. of 6,000 DIN A4 documents/hr.

In order to monitor the positions of the individual documents, the entire transport path is equipped with light barriers.

The figure shows the transport path of the documents in the OSR 330H.

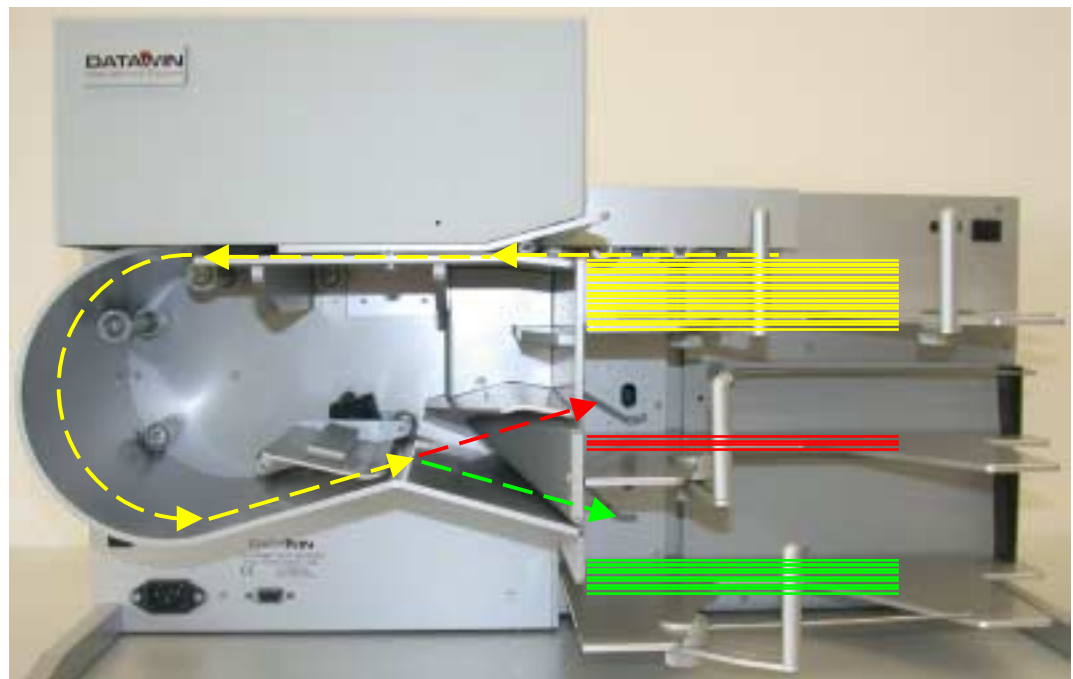

After the documents have passed the read station, the camera, the curved baffle plate and the printer they are deposited in one of the output trays.

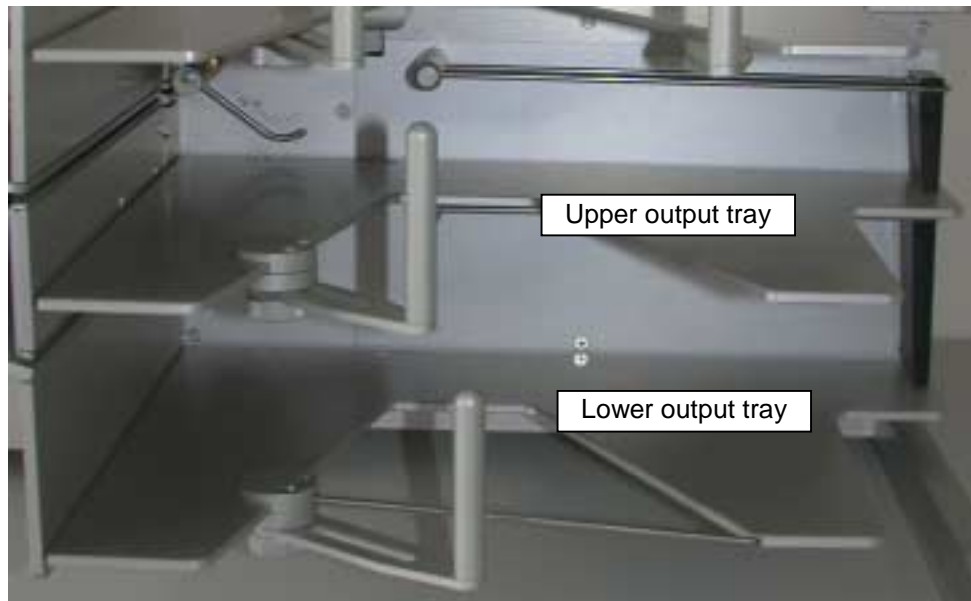

The selection of the output tray is defined in the application program, e. g.: the documents that have been read are placed in the lower output tray, whereby documents with a poor read result - controlled by the sorting deflector - are deposited in the upper output tray (the "bad" tray).

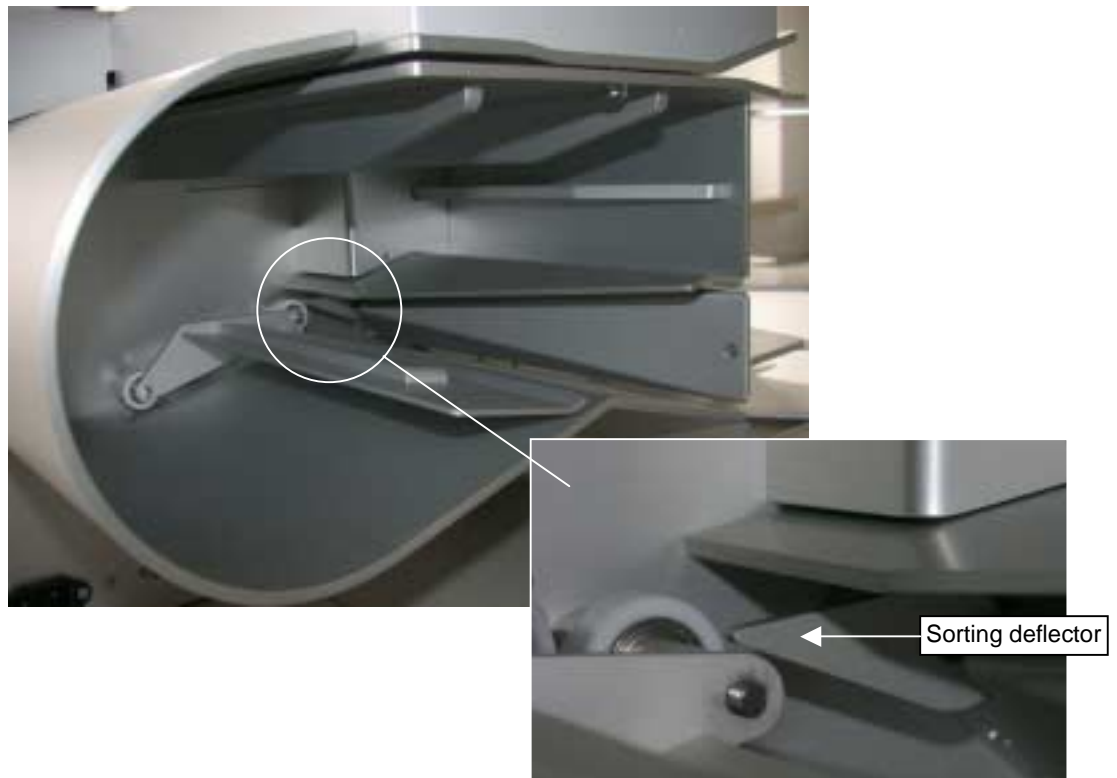

2.2.3 Camera system

A high-resolution color camera with integrated optics and object illumination above the paper path scan the front side of the document. Depending upon the scanning application (software), the resolution amounts to 150 dpi or 300 dpi, without compression or as JPEG; the compression takes place in the scanner.

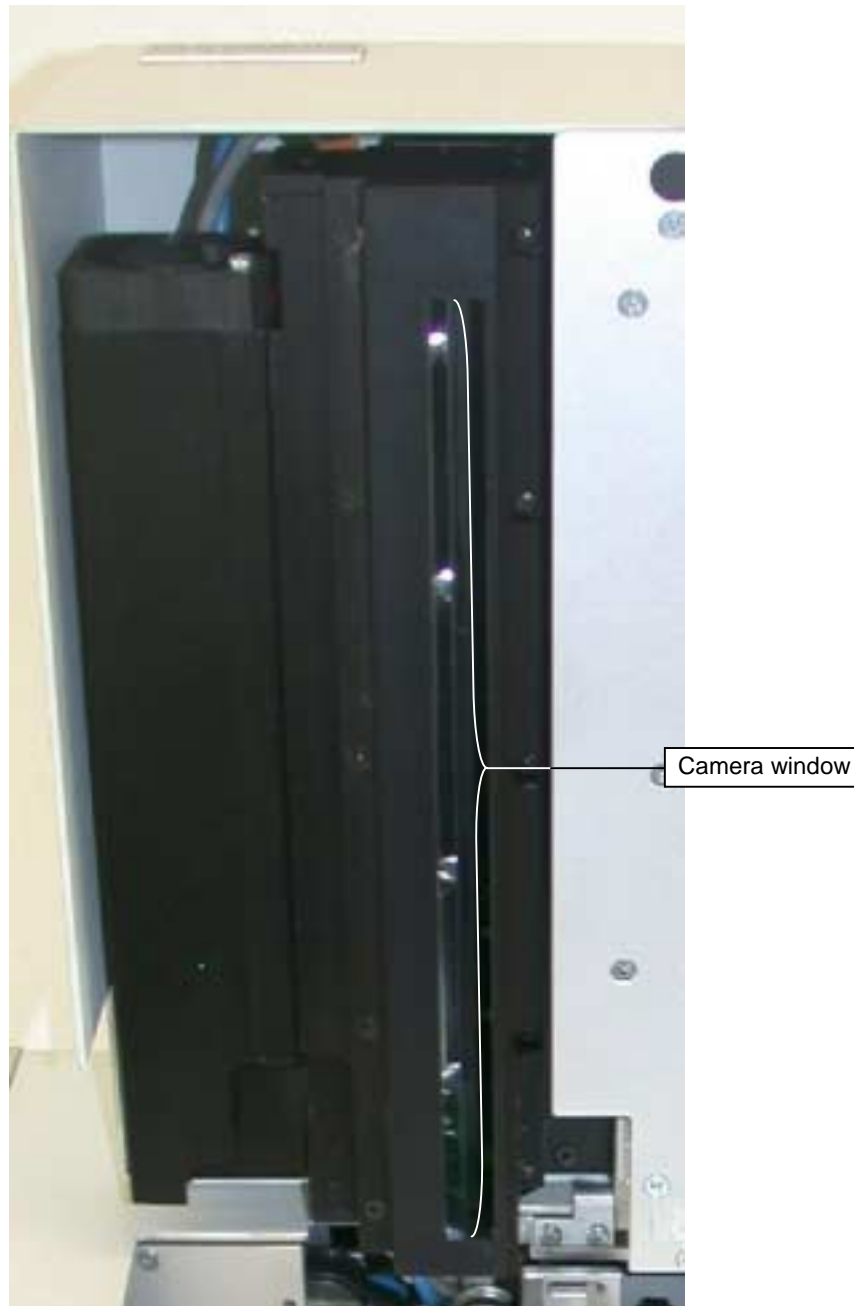

Either color images or alternatively gray scale images as well as binary images are scanned from the front side of the document. In addition, clipped images (snippets) from the front side are also possible.

Scanning is effected with 24-bit color depth.

2.2.4 OMR read head

Depending upon the requirements of the application, the OMR scanning can be designed with infrared or with red light, the mark density amounts to 40 tracks (1/5" interval) or 48 tracks (1/6" interval). To protect against dirt, the scanning strip is located behind a read window.

The scanning strip can be adjusted laterally within a certain tolerance range to compensate for deviations in dimension of the document mark (see section 5.1).

The figure shows the OSR 300H with two OMR read heads to enable reading of the front and rear sides of a document in one run.

2.2.5 Bar code read head

In connection with each OMR read head of the OSR 300H, one bar code read head can be installed as option, as desired for the front side and/or rear side of the document. The read head can be set to cover the entire width of the document (see section 5.2). To protect against dirt, the read head is located behind a read window.

2.2.6 MICR module

The optionally integrated MICR module (MICR = magnetic ink character recognition) reads documents with magnetic fonts, such as e. g. CMC7 or E13B. The MICR module is situated in the upper transport path right behind the document intake. The module consists of a unit for the magnetic biasing of the characters and of the MICR read head.

MICR technology is predominantly used to code bank checks. The read result is made available to the host PC in the form of a data record and can e. g. also be used as sorting criterion for the output tray control in the scanner.

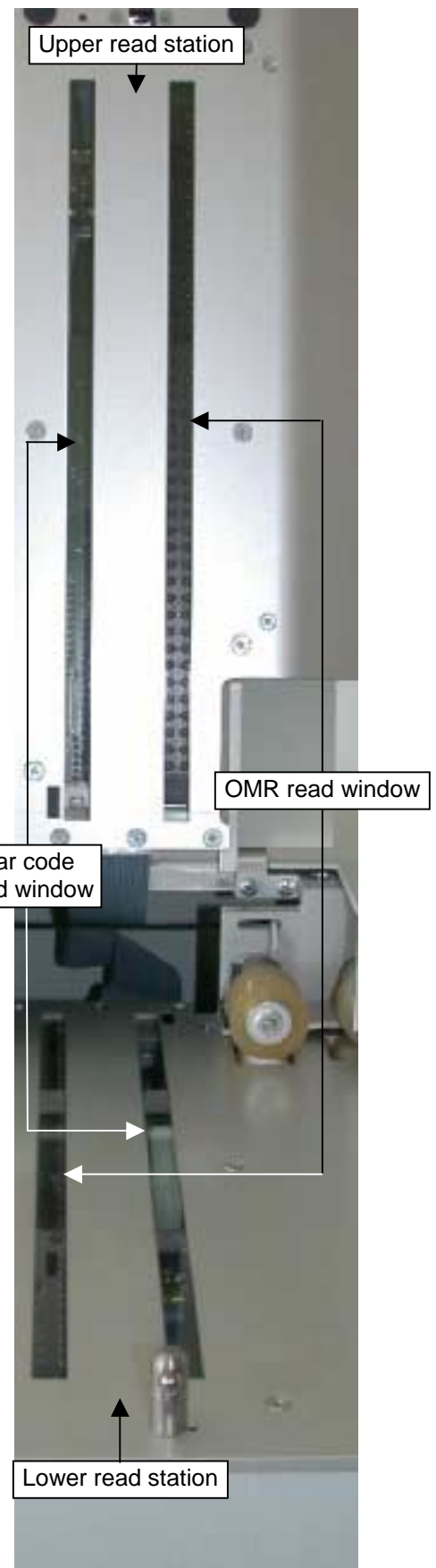

The MICR area that is to be read is parameterized via the scan program. You can find more information on the scan program in the respective manual.

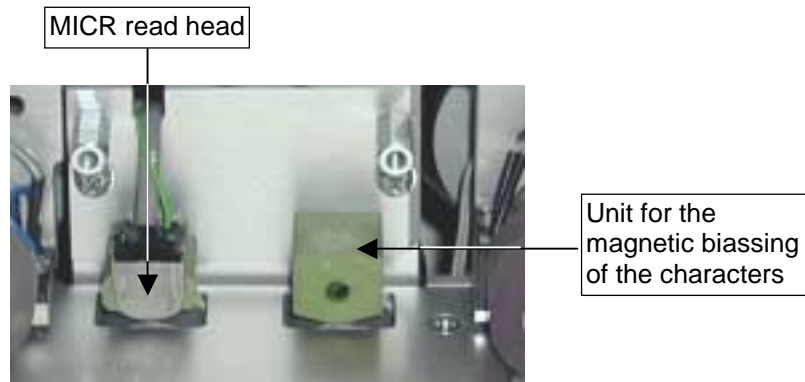

Section 5.5.4 provides details on how to clean the MICR module.

2.2.7 LED display and tray button

Two control lamps show the operating status of the reader (see section 4.2.1). The button enables manual control of the document intake tray.



2.2.8 Optional printer

As an option it is possible to integrate an ink jet printer in the reader. The type used is an HP ink jet printer. The installation position is located in the lower transport path next to the curved baffle plate.



The printer is designed for alphanumeric character output with a density of up to 8 characters/25.4 mm and up to 50 characters per document. The printout is

produced on the rear side of the document. The information to be printed, e. g. a document number or the designation of the processing procedure, is parameterized in the application program. Further information on the application program is to be found in the corresponding manual.

Information on how to exchange ink cartridges is contained in section 5.4.

3 Preparing and installing the reader

This chapter describes how to prepare the reader for initial operation and how to proceed with the installation - from connection to a host (PC) up to conducting a test run.

3.1 Attaching the inclined adjustable feet

You can improve document guidance in the OSR 300H reader if you set it up so that it is not completely level on the work surface, but rather slightly inclined toward the back. For this purpose two spacers are included in the delivery that you can insert into the corresponding bore holes at the front bottom side of the two adjustable feet.



- ◆ Lift the reader slightly at the front by the adjustable feet, “feel” for the bore hole and insert a spacer into the bore hole of each foot until it doesn’t fall out again.



- ◆ Then set the reader down again on the adjustable feet and press uniformly on both feet until the spacers are inserted up to the limiting position in the bore holes.



3.2 Attaching the document stoppers

To ensure proper feeding in and depositing of the documents, you must set the document stoppers to correctly correspond to the size of the documents to be used before you start operation of the reader.

! Please take care to observe the following adjustment criteria.

3.2.1 Intake tray

! Both stoppers on the intake tray must lie flush against the stack of documents, but they may not impede document intake.

- ◆ Place a stack of documents in the intake tray and loosen the stoppers by means of the knurled screws, adjust the stoppers to accommodate the size of the documents to be processed and then fasten them again.

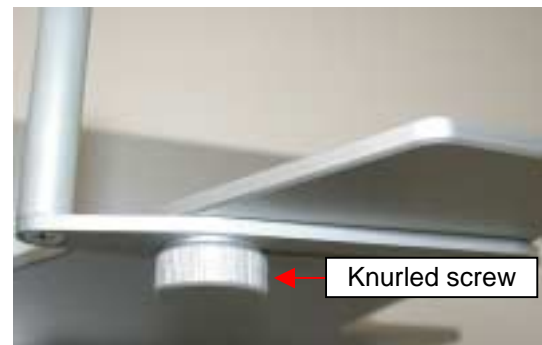

e. g. for large documents...



... or for smaller documents:



3.2.2 Output trays

! The stoppers on the output trays should be positioned at an interval of about 1 to 2 cm from the documents. The documents that are output must be able to fall "freely" onto the output stack.

- ◆ Place a stack of documents in each respective output tray and adjust the document stoppers accordingly.



- ◆ In order to limit the ejection of the documents in the output trays, push the respective black stoppers accordingly and set them so that here as well the documents only have 1 to 2 cm play.



Tip: These stoppers can only be pushed easily against frictional resistance if you grasp them as far as possible near the top.

3.3 Inserting ink cartridges in the (optional) printer

If your OSR 300H is equipped as an option with a printer, you must insert an ink cartridge before initial operation. Use ink cartridges from HP (HP51604A) or other cartridges compatible to these.

You can read about how to insert or exchange the cartridges in section 5.4.

3.4 Mains connection data

The power supply of the OSR 300H is designed for the following voltage and frequency ranges:

- Power supply: 230 V, 50 Hz (0,6 A)
115 V, 60 Hz (1,2 A)
- Current consumption: max. 120 W
(with all options)

Normally no special provisions or settings of the voltage supply are required for the operation of the OSR 300H. However, check whether the existing mains voltage actually corresponds to the values on the type plate of the reader.

3.5 Interfaces

3.5.1 USB interface

The data exchange between the OSR 300H and the PC is handled via a USB 2.0 interface. The USB connector is to be found on the rear panel of the device.

3.5.2 Serial interface

The serial interface of the reader (sub D socket) is used on the OSR 300H for testing purposes only.

3.6 PC connection

3.6.1 Minimum requirements on the PC

- processor: Pentium III processor, 500 MHz or higher
- Microsoft Windows 2000/XP
- screen resolution XGA (1024 x 768) or SXGA (1280 x 1024)
- USB 2.0 interface
- working memory: 256 MB RAM or more
- hard disk memory: 4 GB or more
- CD drive

3.6.2 Installing the software

Descriptions on installing the software (universal scanner interface [USI] and the scan program) on the PC are contained in separate manuals. There you will find detailed information about how to proceed with the set-up of the scanning parameters and what parameterization possibilities are available in connection with the OSR 300H. The read software defines the processing of the OMR marks and bar codes that are read out on the PC. This program is always adapted specifically to the respective application of the OSR 300H.

The manual presupposes that the user has knowledge of the Windows environment along with its control menus and commands via mouse and keyboard.

3.6.3 Connecting the reader and the PC

- ◆ Run down the operating system of the PC.
- ◆ Connect the USB cable to the USB socket of the PC and to the USB socket of the scanner.

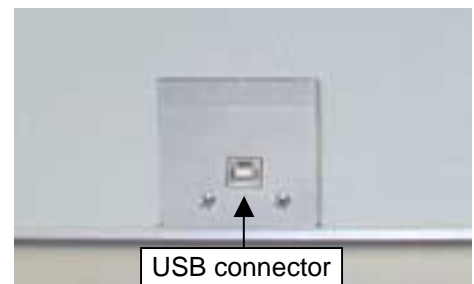

- ! Do not connect the reader to the PC via the serial interface (sub D socket).
- ◆ Connect the mains cable to the connector of the scanner and then plug the mains plug into a mains outlet.
- ◆ Turn on the reader by means of the mains switch.
- ◆ Turn on the PC and run up the operating system.

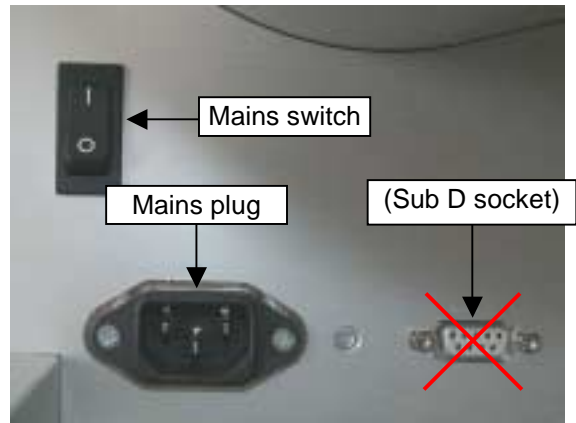

3.7 Testing the read functions

3.7.1 Camera test

Upon completion of the installation steps the scanner is ready for operation and you can test the scanning of the documents. Check thereby if the scanner operates faultlessly and if all the functions are executed in accordance with the intended practical usage.

The manual of the DATAWIN scanning program contains tips and tricks to help you obtain good scanning results fast.

3.7.2 OMR test

Conduct the test only with documents that you will actually use in practical operation. In this regard, also note the document specifications contained in section 6.3.

The special test program "OMR-Test" is also at your disposal for certain tests and functional settings of the reader. The method of operation of this test program is described in the "OSR 300H Technical Operating and Service Manual".

3.7.3 Starting the read process

- ◆ Insert a sufficient number of test documents.
- ◆ Start the read process from the PC.
The stack of documents will automatically be raised to the proper intake height and the first document will be drawn in.

! Since the documents are drawn in from the top, please do not insert more documents while the read process is in progress.

After the last document, the read process will terminate autonomously and the intake tray will be run down to the bottom position.

3.8 De-installing the reader

- ◆ De-install the scanner software on the host PC if it is present.
- ◆ Run down the operating system of the PC.
- ◆ Turn off the reader.
- ◆ Loosen and unplug the connectors of the USB 2.0 data cable at the PC and at the scanner.
- ◆ Unplug the connectors of the reader mains supply cable.

If the device is to be prepared for transportation:

- ◆ Remove the ink cartridge from the printer (see section 5.4).

4 Operation of the reader

This chapter provides you with tips and information to assure faultless operation of the OSR 300H.

4.1 Loading the stack of documents

After the reader has been turned on and the last document processed, the document intake tray runs down to the lowest position so that documents can be inserted. You can also run the stacker tray upwards or downwards alternately by pressing the tray button.

- ◆ Take a properly aligned stack of documents (approx. 100 sheets) and place it in the intake tray so that it is flush at the left and at the back sides of the housing.



The document intake tray can accommodate up to 500 sheets (80 g/m²); the height of the stack, however, should not noticeably cause the pair of feed rollers to be raised.

4.2 Starting the read process

- ◆ Start the read process from the PC.

The stack of documents will automatically be raised to the proper intake height and the first document will be drawn in.

- ! Since the documents are drawn in from the top, please do not insert more documents while the read process is in progress.

After the last document, the read process will terminate autonomously and the intake tray will be run down to the bottom position.

4.2.1 Display of the operating status

The following table shows the standard displays:

LED		Significance
Red	Green	
steady-burning	steady-burning	Power on Before initialization.
blinking	steady-burning	At the end of initialization (approx. 20 sec. after pressing the mains switch).
off	steady-burning	Ready After insertion of documents and enabling by the tray button.
Both LEDs blinking simultaneously		An output tray is full; (blinking until the stack has been removed; acknowledge by the tray button).
Both LEDs blinking alternately		Transportation fault, document intake or ejection jam or double document; (blinking until the fault has been eliminated; acknowledge by the tray button).

- ! It is possible that other operating modes or display statuses are parameterized by the application software. In that case, they are documented in a special software description.

4.3 Eliminating document jams

The faultless isolation of the documents and their correct feeding in is monitored by light barriers. This prevents two documents from being drawn in at the same time.

In the transportation path as well, the position of the documents is determined and monitored by light barriers. If a document gets jammed in the paper pathway during transportation, this is detected by the missing presence of the document at the corresponding light barrier and the read process is interrupted.

Reasons for document jamming may be e. g. very wrinkled, glued together or soiled documents. Always eliminate the disturbance by carefully removing the jammed document or foreign object (e. g. paper clip or shredded paper particles).

4.3.1 Opening and closing the scanner cover

- ◆ Grasp the scanner cover at the front document intake area and lift it upwards. Fold the cover towards the back until it comes to rest on the housing.
- ◆ To close it again, swing the scanner cover forwards, until it is clear that the guide pin of the base plate has locked into place.



! Please do not allow the cover to fall backwards onto the housing when opening it, nor to fall forwards onto the base plate when closing it.

4.3.2 Removing documents

- ◆ Carefully remove all documents that are located in the paper pathway and ascertain the cause of the document jam (e. g. wrinkled document, dog-ears, poorly glued bar code label).

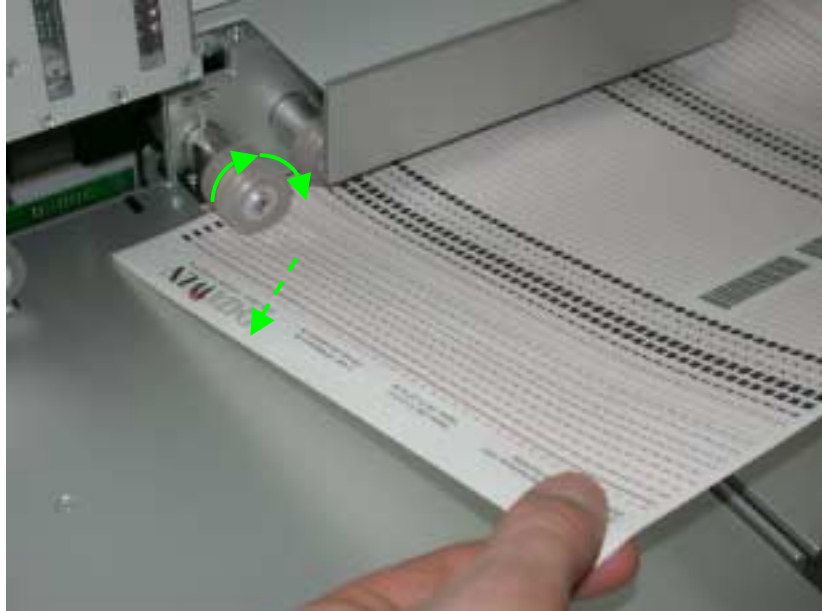

- ◆ When possible, always remove the document in the direction of the transport path. If necessary, turn the double intake roller with your thumb and pull the respective document carefully out of the transport roller towards the front; the other transport rollers will move accordingly.
- ! Pulling jammed documents in the direction opposite to that of the transport path may cause them to be damaged by guide plates that are designed for forward movement.
- ◆ Replace in the intake tray the documents caught in the jam and possibly any other documents to be fed in and restart the read process.

4.4 Trouble shooting

Problems that may possibly arise are listed in the following table. The measures described often help to eliminate the errors.

Problem	Measure
OMR read errors	
Recognition of the marks is becoming increasingly poorer	<ul style="list-style-type: none"> ◆ Check if the scanner is dirty. If necessary, clean the covers (protective glass covers) of the read heads (see section 5.5.3). ◆ Check if the lateral setting of the scanner is correct or if it possibly should be adjusted (see section 5.1).
Marks are partially not recognized, especially at the beginning and/or end of the document	<ul style="list-style-type: none"> ◆ Check if the edges of the documents are straight. ◆ Check if the transport rollers are dirty (see section 5.5.1).
Marks are recognized at places where there are no marks, especially at the beginning and/or end of the document	<ul style="list-style-type: none"> ◆ Check if the edges of the documents are straight. ◆ Check if the transport rollers are dirty (see section 5.5.1).
Document transport	
No documents are drawn in	<ul style="list-style-type: none"> ◆ Open the scanner cover and check the transport path. Remove any foreign objects without force. ◆ Smooth out the document and flatten down dog-ears if applicable. ◆ Check if bar code labels are not properly glued or if they are turned up at the corners. ◆ Check whether the application software is running. Is the feed-in command from the PC missing or was the data of a document previously read not called? ◆ Turn the reader off and after about 3 sec. turn it on again. Start the PC again according to the software description.
The document is drawn in but is not scanned completely. The ejection behavior is not defined.	<ul style="list-style-type: none"> ◆ Check if the transport rollers are dirty (see section 5.5.1). ◆ Contact your supplier if you are using documents that have clock marks that are wider than those prescribed and that thus do not correspond to the document specification.

Problem	Measure
Document output	
<p>The document is drawn in correctly, the read data is transmitted to the PC, but the reader does not output the document. Only after a document has been removed manually is the next document drawn in.</p>	<p>If none of the measures described above have helped:</p> <ul style="list-style-type: none"> ◆ Clean all the light barriers in the transport path (see section 5.5.2). ◆ Check if the interface cable is firmly connected. <p>If these measures still do not remedy the situation:</p> <ul style="list-style-type: none"> ◆ Please contact DATAWIN: <p>Hotline: +49 17 33 87 45 27 Fax: +49 871 43 05 99 29 Email: service@datawin.de</p>

5 Setting, adjusting and cleaning the reader

This chapter describes how you can set the read stations by means of simple mechanical adjustments to correspond to the documents to be read. Moreover, you will learn how to set the document isolation and how to clean the device without great effort to increase the read accuracy. For these operations you will need a cross-tip screwdriver (size 1, 300 mm) as well as two hexagon socket screw keys (1.5 and 2.5 mm). These tools are included in the scope of delivery of the OSR 300H.

5.1 Setting the OMR read head

In the manufacture and printing of mark documents a particular dimensional field must be exactly adhered to. Besides this, the clock mark track and the marking area must run exactly parallel to the edge of the document that is transported along the document stopper during the read process. On documents that are printed or cut askew, the clock mark track and the marking area are spread across the entire document outside of the dimensional field. These deviations in dimension can be compensated within a certain tolerance range by means of a lateral "shifting" of the OMR scanning strip.

5.1.1 Basic setting "standard document"

The mark scanning is set at the factory to correspond to a "standard document". The table below shows the distances (in mm) based on a sample of 40 track scanning with mark spacing of 1/5". The dimensions **A** and **H** are decisive for the correct lateral setting of the OMR read head. When these dimensions, due to inaccurate printing or cutting of the documents, are smaller or larger (deviations max. -1 to +3 mm), compensation can be achieved by corresponding adjustment

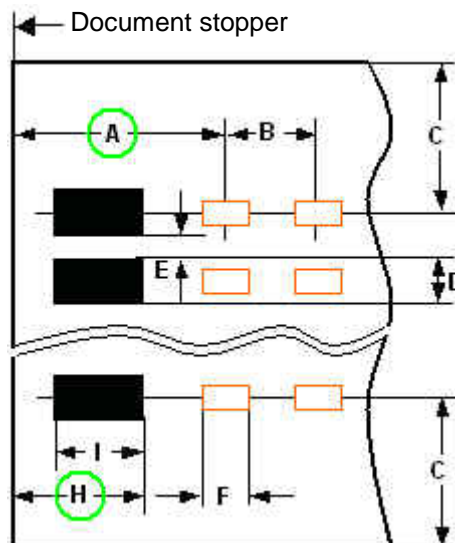

	min.	norm.	max.
A		13.97	
B		5.08	
C	10		
D	1		4
E	1.5		
F		3.0	
G	10		
H		7.62	
I		5.08	

The read head must be adjusted when marks on the document (even quite solid marks) that do not fill out the entire width of the mark field, are not scanned at all or are only scanned in an inaccurate manner. It is also typical that marks are recognized although they are actually too short or are situated clearly off-center in the mark field.

5.1.2 Adjusting the lateral setting of the OMR read head

- ◆ Open the scanner cover.
The position at which the document stopper is located during the read process is designated by a reference line on the base plate of the read head. On the front side of the scanner cover there is an opening for the setting screw of the scanning strip.
- ◆ Insert the hexagon socket screw key into the opening and turn it
 - clockwise: the scanning strip is set further away from the edge of the document (edge with the clock mark), that is, away from the reference line.
 - counter-clockwise: the scanning strip is set closer to the edge of the document (edge with the clock mark), that is, closer to the reference line.

With one rotation of the hexagon socket screw key the scanning strip is shifted by 0.5 mm in the respective rotational direction.

Additional information about adjusting the scanning strip is to be found in section 5.1.4 “Effect of the read head setting on the scanning result”.

- ◆ Subsequently conduct a test run with original documents to check the setting of the read head.

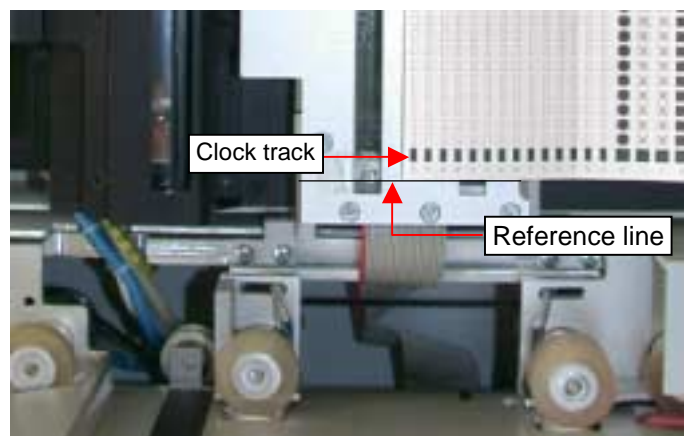

5.1.3 Adjusting the lateral setting of the lower OMR read head (option)

- ◆ Open the scanner cover.

At the front of the lower scanner cover there is also an opening for the setting screw for the adjustment of the scanning strip:

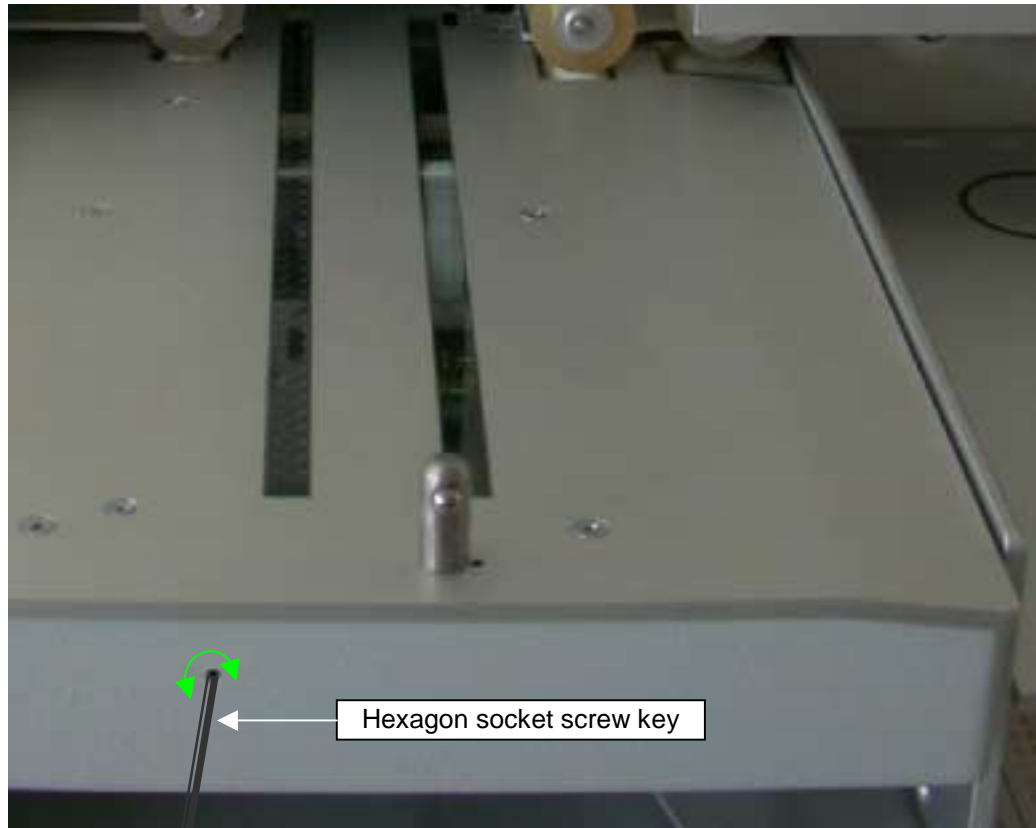

- ◆ Insert the hexagon socket screw key into the opening and turn it
 - clockwise: the scanning strip is set further away from the edge of the document (edge with the clock mark), that is, away from the reference line.
 - counter-clockwise: the scanning strip is set closer to the edge of the document (edge with the clock mark), that is, closer to the reference line.

With one rotation of the hexagon socket screw key the scanning strip is shifted by 0.5 mm in the respective rotational direction. Additional information about adjusting the scanning strip is to be found in section 5.1.4 “Effect of the read head setting on the scanning result”.

- ◆ Subsequently conduct a test run with original documents to check the setting of the read head.

5.1.4 Effect of the read head setting on the scanning result

On the basis of examples of various mark types and mark positions the following table shows how the scanning result is dependent upon the lateral setting of the read head. The test points (examples 4, 5, 6, 7) are also to be found on the DATAWIN test document, with the aid of which you can quickly obtain information about the setting of the read head and accordingly correct the setting of the scanning strip.

Marking examples:

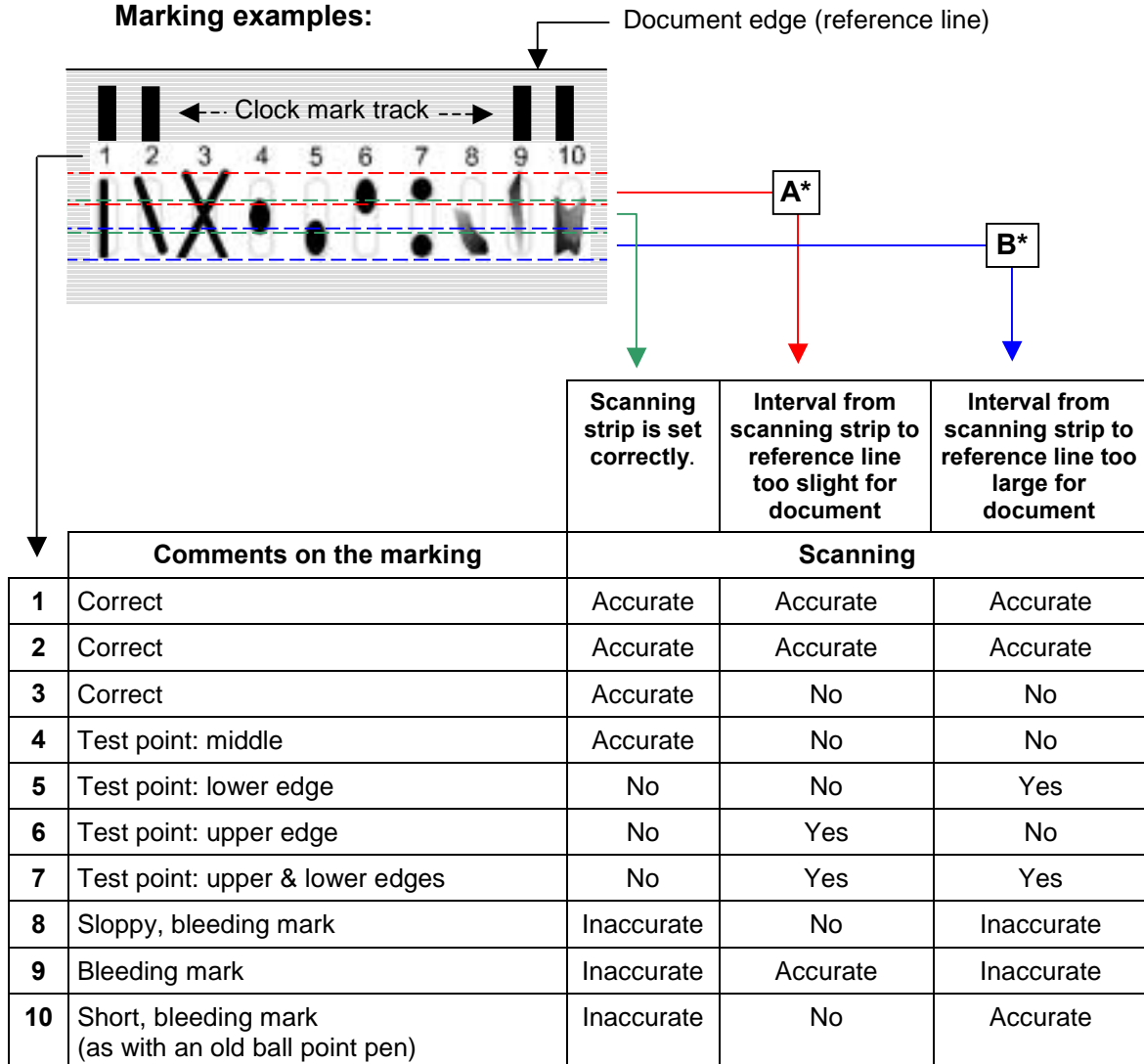

*)

! A

If the interval from the scanning strip to the reference line is too slight, **enlarge** the size of the interval by turning the hexagon socket screw key **clockwise**.

! B

If the interval from the scanning strip to the reference line is too large, **reduce** the size of the interval by turning the hexagon socket screw key **counter-clockwise**

5.2 Setting the bar code read head (option)

To achieve proper recognition of the bar code, the bar code read head must be positioned over the area to be read - as far as possible in the middle - while the document is being transported.

You can easily check the setting of the bar code read head and, if necessary, correct it:

- ◆ Open the scanner cover.
- ◆ Place one of the bar code documents to be processed on the scanning unit in such a manner that the edge on which the clock track is located lies flush along the reference line of the base plate. (This reference line identifies the position at which the document stopper is located during the read process).

There is an opening located next to the window of the bar code read head; the adjusting screw for the read head is behind this opening:

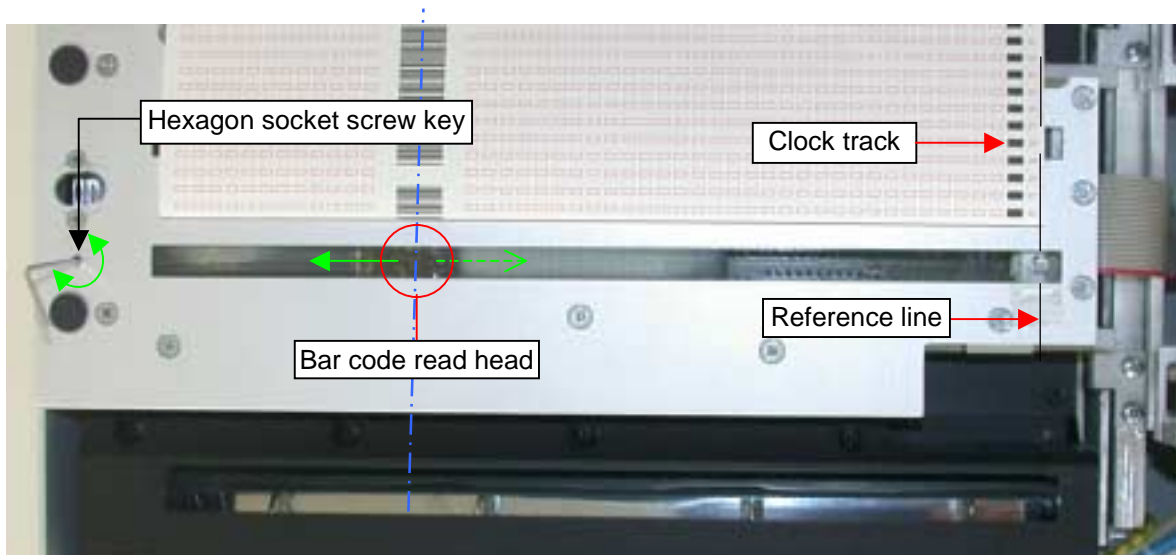

- ◆ Insert the hexagon socket screw key into the bore hole and by turning the key, position the bar code read head above the middle of the bar code that is printed or glued onto the document.

5.3 Setting the document isolation

The document isolation is designed for a wide variety of paper qualities and surfaces and it thus operates very reliably. The two feed rollers by means of their turning, draw off the first sheet of paper from the stack of documents and guide it into the feed-in slot and then on to the intake roller. The separating belt lying below the intake roller moves slowly and contrary to the direction of the document; it brakes additional sheets if they are also drawn in and restrains them. The interval between the separating belt and the intake roller is adjustable.

Normally the interval must only be corrected if the automatic intake unit does not function satisfactorily due to the thickness of the documents being processed. Before you adjust the separating belt because of unreliable drawing in of the documents, first check the interval between the belt and the roller:

- ◆ Open the scanner cover.
- ◆ First of all clean the feed rollers, the intake roller and the separating belt (see section 5.3.1) with a cloth that is lightly saturated with spirits of wine and then test the intake behavior. **Only in the event that you do not notice an improvement, take the following steps:**

- ◆ With lowered stack feed, insert a document between the intake roller and the separating belt.
- ◆ Move the sheet of paper back and forth. It should be possible to move the sheet easily and smoothly without rubbing and it should be free of play. If the result is not satisfactory, you must adjust the separating belt accordingly. As tool you will need a hexagon socket screw key 2.5 mm.



- ◆ First of all, "close" the document isolation by turning the adjusting screw counter-clockwise until the document is tightly clamped between the intake roller and the separating belt. This is fundamentally necessary before all adjustment operations in order to initially release the tension on the spring system of the document isolation.



- ◆ Now turn the screw carefully in clockwise direction until the document can be moved easily without much friction, but still without play.
- ◆ Then to check the setting, attempt to push **two** sheets of paper, one on top of the other, between the intake roller and the separating belt. Strong resistance must be noticeable.

The document isolation is then set correctly.

! The error often occurs that the interval between the roller and the belt is set too narrowly.

5.3.1 Cleaning the separating belt

- ◆ To clean the separating belt, saturate a lint-free cleaning cloth lightly with spirits of wine and press the cloth against the outer surface of the separating belt. By manually turning the double transport roller you can simultaneously turn the belt until it is cleaned.

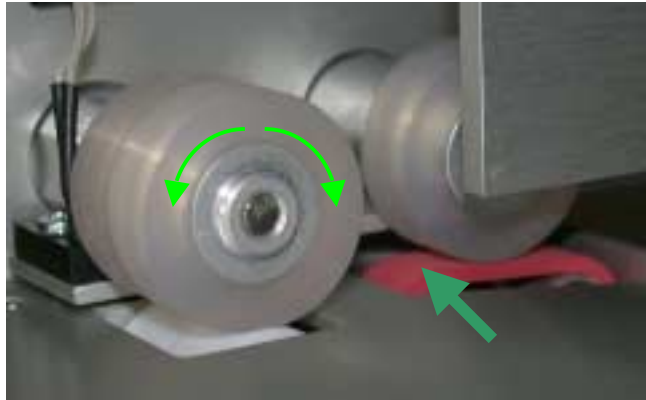

! When you are working with spirits of wine, be sure that there are no burning objects (cigarettes or similar) in the environment of the working place.

5.4 Replacing ink cartridges in the printer

The printer is located in the lower transport path next to the curved baffle plate.



- ◆ Remove the guide plate by pulling it **straight towards the front** out of its holder.



A clip locks the installed ink cartridge in place in the printer.

- ◆ Tilt the clip backwards and lift out the cartridge towards the top.
- ◆ Place the new cartridge in the printer and tilt the clip forwards again.



- ◆ Remount the guide plate.
To do so, set the pins back into their sockets and press the guide plate down again until it rests into place and lies flat.



The printer is again ready for operation.

5.5 General information on cleaning the OSR 300H

DATAWIN document readers are designed for ease of maintenance. Very few maintenance and service operations are necessary and these can be carried out to a great extent without tools. It is only hypothetically possible to specify cleaning cycles since soiling and also wear and tear of the individual components of the reader depend largely on the operating and ambient conditions of usage, such as

- dust contents, humidity and flow of the ambient air,
- abrasive properties of the document materials and printing,
- general degree of soiling of the documents,
- daily volume of documents processed,
- weight of the documents.

Cleaning cycles may be established based on empirical values gathered in the course of regular optical checks and from the cycles of read errors that require maintenance operations. For readers that are used in conditions that are not extremely inclement, cleaning of the transport system should be effected after approximately **100,000** documents have been read.

Even for devices that are not in regular operation, dust accumulates on the silicone rollers that is pressed and compacted during subsequent read processes and that then leads to smoothing and hardening of the surfaces.

! Independent of the volume of documents processed, you should therefore clean the transport rollers regularly **at least once a month**.

This routine cleaning requires about 5 minutes time; no special tools are needed.

- **Transport rollers** and the **read window** are cleaned with
 - methylated spirits (or alcohol),
 - cotton swabs,
 - and a lint-free cloth.
- **Light barriers** and **transport slits** should be blown out. To do this you can use the following
 - a compressed air can (available at photo shops) or
 - a vacuum cleaner with a narrow nozzle,
 - (or, instead of these you can simply blow them out forcefully yourself!)
- **Housing surfaces** and the **surfaces traversed by the documents** can best be cleaned with
 - **silicone-free** hard wax from an automotive supplier.

! **When you are working with spirits of wine, be sure that there are no burning objects (cigarettes or similar) in the environment of the working place.**

5.5.1 Cleaning the transport rollers

- ◆ Turn the reader off and open the scanner cover.
- ◆ Using a cotton swab that has been saturated with spirits of wine (it may be strongly saturated), clean the silicone rollers. If necessary, turn the double transport roller with your thumbs; all the other rollers will also turn accordingly. Change swabs as soon as they become soiled.

! When you are working with spirits of wine, be sure that there are no burning objects (cigarettes or similar) in the environment of the working place.

! If you turn the transport roller by hand, please take care to assure that the cotton swab is not pulled in between the pressure roller and the silicone rollers.

5.5.2 Cleaning the light barriers

In general the light barriers are not very susceptible to soiling. However, in case you are using documents that are particularly affected by dust and produce rubbed-off particles, it may happen that such particles collect and they may unfortunately be deposited right in front of a light barrier.

- ◆ Turn the reader off and open the scanner cover.
- ◆ Clean the light barrier windows using a sturdy brush, compressed air or a vacuum cleaner (or simply a forceful breath of air).

5.5.3 Cleaning the read windows (camera, OMR and bar code)

- ◆ Turn the reader off and open the scanner cover.
- ◆ Rub the camera and the read windows clean using a lint-free cloth (in case of persistent dirt, possibly saturate the cloth with spirits of wine). Take care to assure that all residues of correction fluids and glues have definitely been removed.

5.5.4 Cleaning the MICR module (option)

- ◆ Saturate a lint-free cloth lightly with spirits of wine and draw it carefully several times underneath the read head and under the magnetic biasing unit.

! When you are working with spirits of wine, be sure that there are no burning objects (cigarettes or similar) in the environment of the working place.

5.5.5 Cleaning the housing surface

- ◆ Use a brush or similar to free the surfaces of the reader housing from dust. In addition, long-term protection can be achieved if you apply **silicone-free** hard wax to the surfaces.

The operating behavior of the reader will be positively influenced if you also polish

- the guide plates in the scanner cover,
- the document bed of the intake tray and
- the document stoppers

with **silicone-free** hard wax. Your reader was also treated with this wax before it was delivered.

- ◆ If the surfaces of the document transport path no longer permit easy gliding of the documents because they have become soiled, you can optimize the route that the documents traverse by renewed polishing.

! In carrying out these operations, be absolutely certain that the parts of the transportation mechanics (all rotating parts of the reader) **do not come in contact with the wax**. For safety sake, when polishing the surfaces that the documents pass across in areas near the read windows, cover the respective rollers with paper. If despite this, rollers come into contact with the wax, you must clean them again very carefully with spirits of wine.

6 Requirements on the documents

This chapter describes the requirements on the documents to be processed and provides tips on the OMR marks to ensure smooth operation of the OSR 300H.

6.1 External characteristics

Good read results presuppose good quality of the documents to be processed. Therefore, certain minimum requirements must be taken into consideration.

Prerequisite for the accurate scanning of the marks on the documents is a straight and unimpaired transportation of the documents through the reading stations.

The external characteristics of the documents to be read are also important:

- ! Do not place any wrinkled, rolled or folded documents in the reader. If necessary, smooth out the document beforehand and eliminate any dog-ears.
- ! The use of correction fluids is forbidden! Nevertheless, in the event that a document was treated with correction fluid, please assure that the fluid has dried completely. Otherwise there is danger that dirt may pass into the transportation mechanism and into the scanning unit which could lead to reading inaccuracies.
- ! Improperly glued bar code labels may also cause transportation disturbances and document jams. Therefore, please press down the edges of the labels firmly.
- ! **Be certain to observe the correct settings of the document stoppers in the intake tray and in the output trays** (see section 3.2).

6.2 Prescriptions and recommendations concerning OMR marks

6.2.1 The mark field

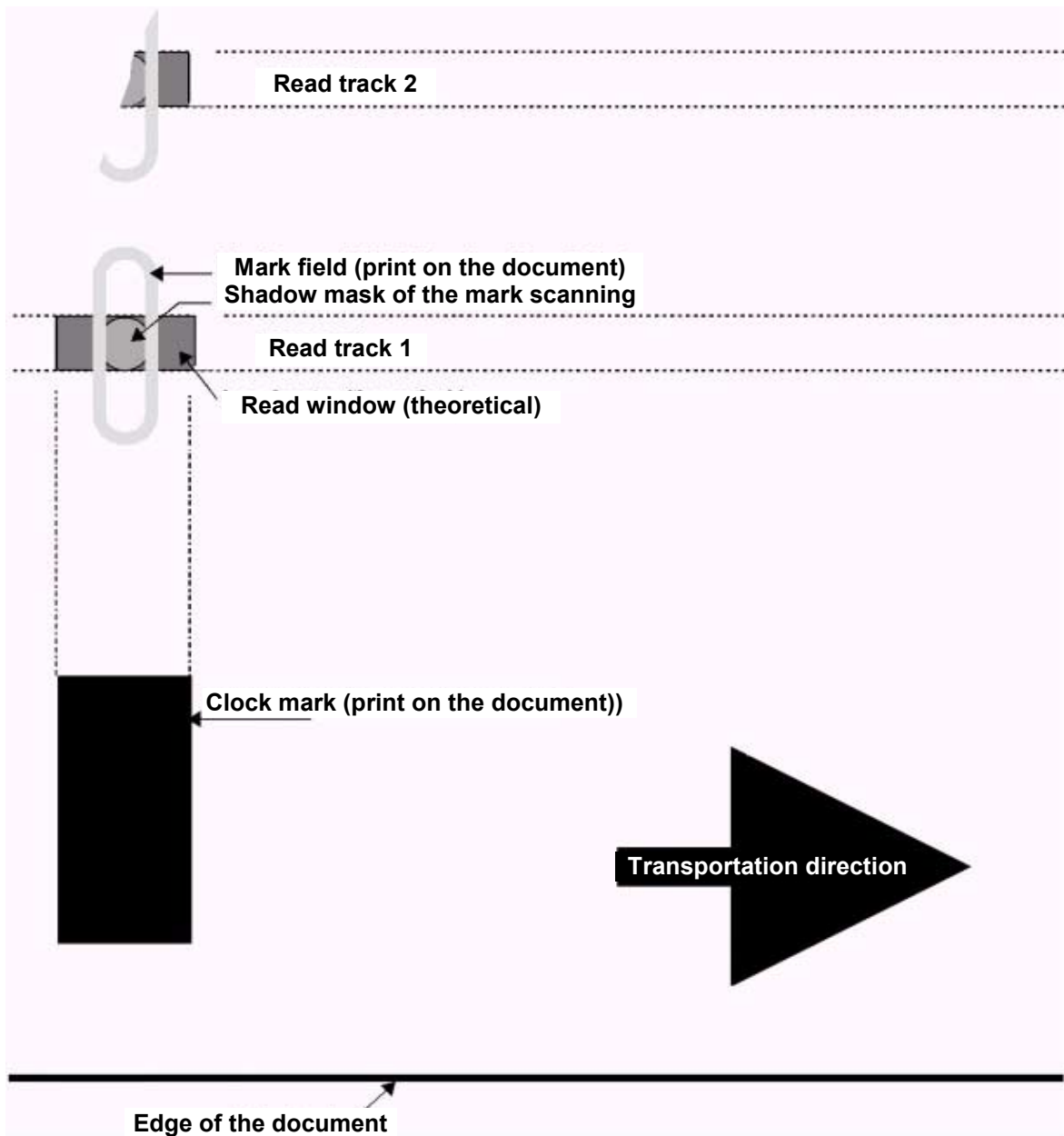

The mark field identifies the position of the mark on the document. Inside the mark field the position of the scanning window is determined by

- the grid size of the mark scanning specified by the reader (here 1/5" interval from one read track to the next read track),
- the clock mark width (document design) and
- the size and form of the scanning mask (shadow mask).

6.2.2 Correct marks

A shadow mask with a diameter of 1 mm is used in the OSR 300H. This ensures the exact separation of the individual tracks and at the same time it enables the acquisition of marking crosses. Moreover, because of the scanning that strongly emphasizes the middle section, miscut documents, off-center marks and marks that protrude are compensated for by means of generous tolerances. However, for this it is prerequisite that the entire mark field is utilized for the marks:

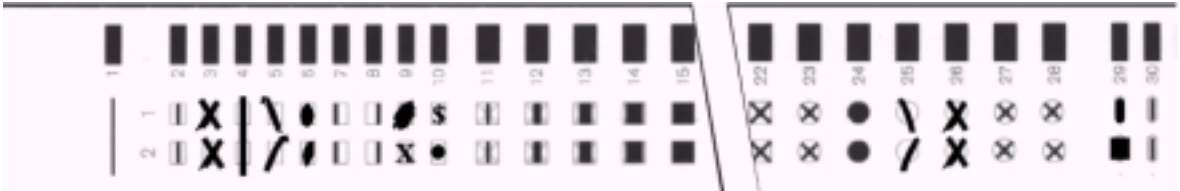

Both the position and the size of the read window can be influenced to a great extent by means of the parameterization of the reader in the interface program.

! As basic principle however, the following applies: a mark can be recognized **only** in the **read window** depicted above. Therefore, the better that the mark field is filled by the mark (bar, cross) across the entire length, the more accurately will this mark be recognized under unfavorable circumstances (unsteady document transport, documents cut or printed off straight). And also - the firmer the mark is, the more accurately can the automatic interference masking select a mark and distinguish it from surrounding document dirt.

6.2.3 Inadmissible marks

Several typical marking errors are displayed here:



! **Continuous marks are not permissible!**



A white interval of at least 1 mm must be maintained between the marks.

6.2.4 Reliable marking instruments

The table below shows which marking instruments are best suited for the respectively utilized signal (infrared / red light).

Marking instrument	Utilized Signal	
	Infrared scanning	Red light scanning
Pencil HB	very good	very good
Pencil H	good	good
Pentel marker	useless	very good
Staedler 318	useless	very good
Ball point pen black	dubious	good
Ball point pen blue	useless	good
Ball point pen green	useless	good
Ball point pen red	useless	useless
Endorsing ink violet	no signal	dubious
Endorsing ink blue	no signal	very good
Toner *	very good	very good
Printing ink *	very good	very good

* for preprinted marks, e. g. document type

The clock mark is always scanned with infrared light, independent of the signal utilized by the mark scanning.

6.3 DATAWIN OMR document specifications

(Version 040615)

6.3.1 Standard document

Standard document 12 (16) tracks, spacing 1/4"

(All dimensions in mm)

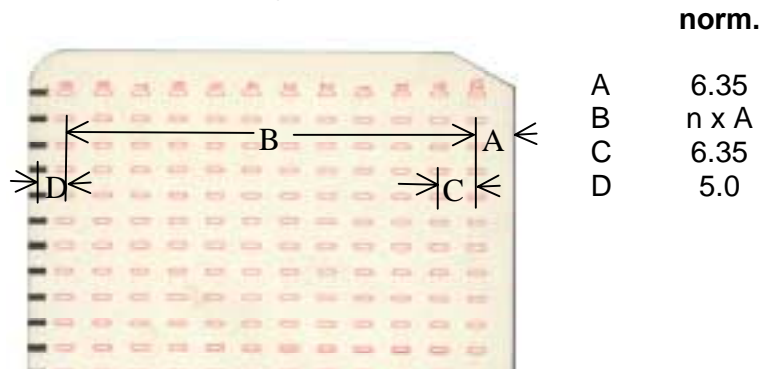

Standard document 40 tracks, spacing 1/5"

Standard document 16 (18) tracks, spacing 1/5"

(All dimensions in mm)

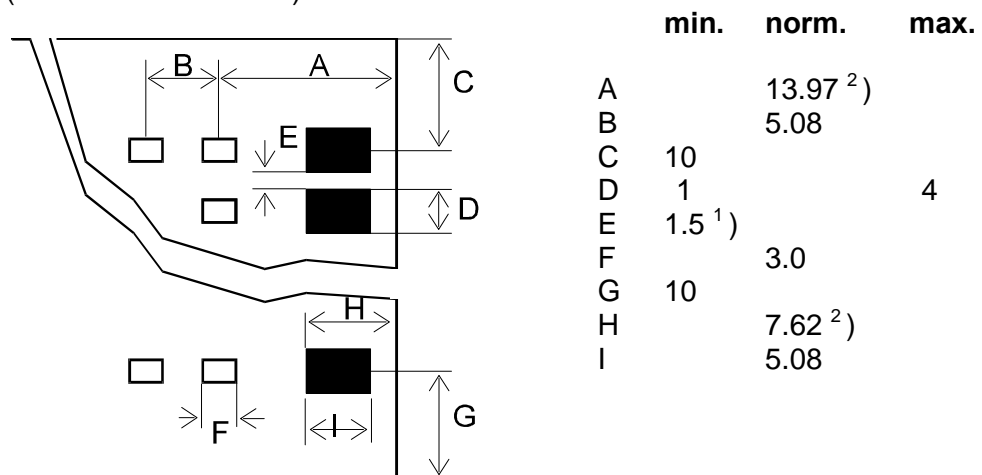

Standard document 48 tracks, spacing 1/6"

(All dimensions in mm)

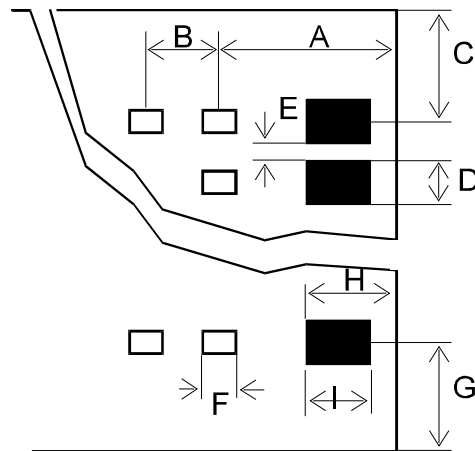

	min.	norm.	max.
A		11.43 ²⁾	
B		4.23	
C	10		
D	1		4
E	1.5 ¹⁾		
F		3.0	
G	10		
H		8.89 ²⁾	
I		3.81	

¹⁾ Can be smaller for special coding techniques, according to the manufacturer.

²⁾ DATAWIN mark readers permit a scanning shift of -1 +3 mm.

However, the dimensions A and H must then deviate in the same direction and by the same values.

Document quality

Mechanical properties as per DIN 6723/6724

Optical features: OCR quality as per DIN 66223

PCS value for clock marks: > 60%

Document format

(length in transport direction > width!)

Type of reader	Min. document (mm)	Max. document (mm)	Paper weight (g/m ²) As per DIN 19307
OSR 300H	110 x 50	305 x 230	80 - 140

6.3.2 Scanning window

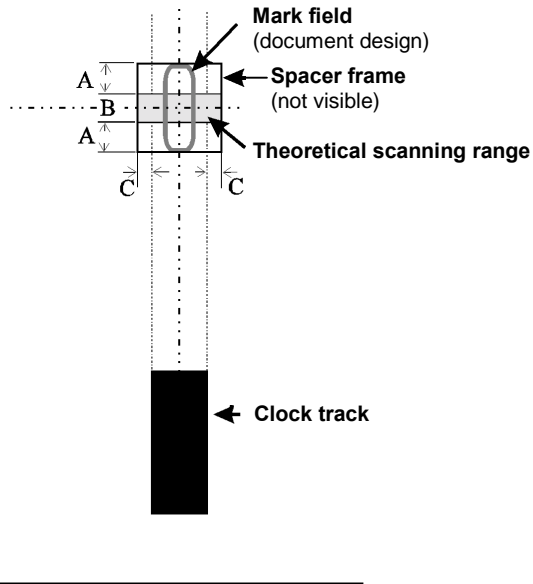

Dimensions: A = min. 1.0 mm
B = 1.0 mm
C = min. 0.5 mm

Marks (and readable print on documents) are recognized in the "theoretical scanning range" shown on the left.

If no specific scanning procedures are used to mask black print (scan mode, window definition), it is recommended that no readable inscriptions and graphics be applied in the area of the displayed "spacer frame".

The spacer frame is dimensioned in such a manner that minor deviations in document design, cut and transport are compensated.

6.3.3 Bar codes labels and imprints

Dimension (s. sketch)	Designation	Min. mm	Max. mm	Comment
A	Distance to document end	35	–	Distance of last bar code module to document edge
B	White margin	10	–	Area before the first and after the last bar code module that must be white or in blind print
C	Distance between 2 bar code tracks	11	55	Only for "double bar code" option. Greater distances on request. Please note: the distance requested by the customer is set in the factory and cannot be changed.
D	Distance to lower edge of the doc – OSR 300H	18	195	Distance of the bar code module to the lower edge of the document. The area of the clock marks must always remain free!

During the scanning of the bar code by the document reader, the bar code read head must be able to scan the whole bar code in at least one diagonal. Therefore it is best in any case to print the bar code as high as possible in order e. g. to be able to compensate gluing inaccuracies.

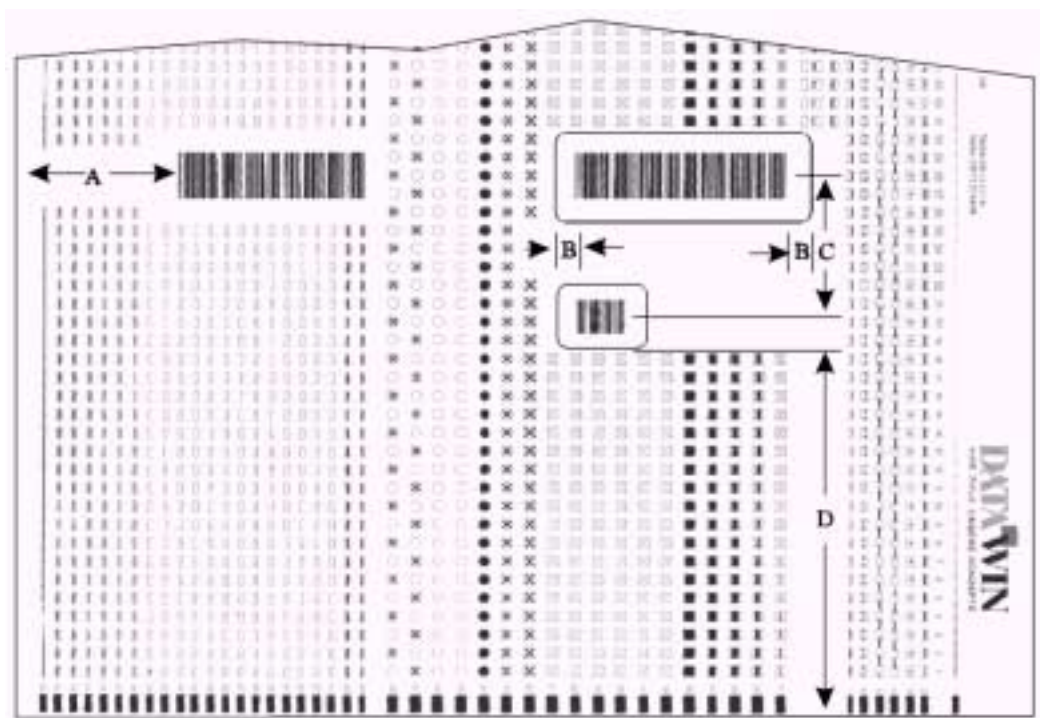

6.3.4 Permissible document colors for red light and infrared light scanning

Measurements with blind colors of the ink manufacturer "Zeller & Gmelin"
(% specification corresponds to the blind color unwanted signal)

Scanning:		infrared light: 950 nm	red light: 635 nm		
Print color	Color no.	Value %	Comment	Value %	Comment
paper	white	< 1		< 1	
yellow	63376	3	good	4	still good
yellow	64400	3	good	4	still good
yellow	64401	< 1	very good	< 1	very good
orange	63079	2	very good	4	good
red	62429	2	very good	< 1	very good
red	63082	2	very good	4	still good
red	63112	2	very good	4	still good
red	65108	< 1	very good	< 1	very good
red	65204	< 1	very good	4	still good
red	65205	2	very good	4	still good
violet	63081	3	good	12	dubious
blue	62432	3	good	44	useless
blue	63893	2	very good	32	useless
blue	65107	2	very good	16	poor
blue-green	63892	3	good	44	useless
blue-green	65109	< 1	very good	24	useless
green	62431	3	good	48	useless
green	63483	< 1	very good	44	useless
green	63505	3	good	36	useless
green	64513	3	good	80	useless
yellow-green	63891	3	good	48	useless
brown	62433	4	still good	16	poor
brown shade (1 g/m ²)	18482	2	very good	24	useless
brown shade (2 g/m ²)	18482	2	very good	40	useless

The blind color "violet", classified under red light as "dubious" should be avoided if possible or only used after consultation with the manufacturer!